

# DASAG

Verfahrenstechnik  
Anlagenbau

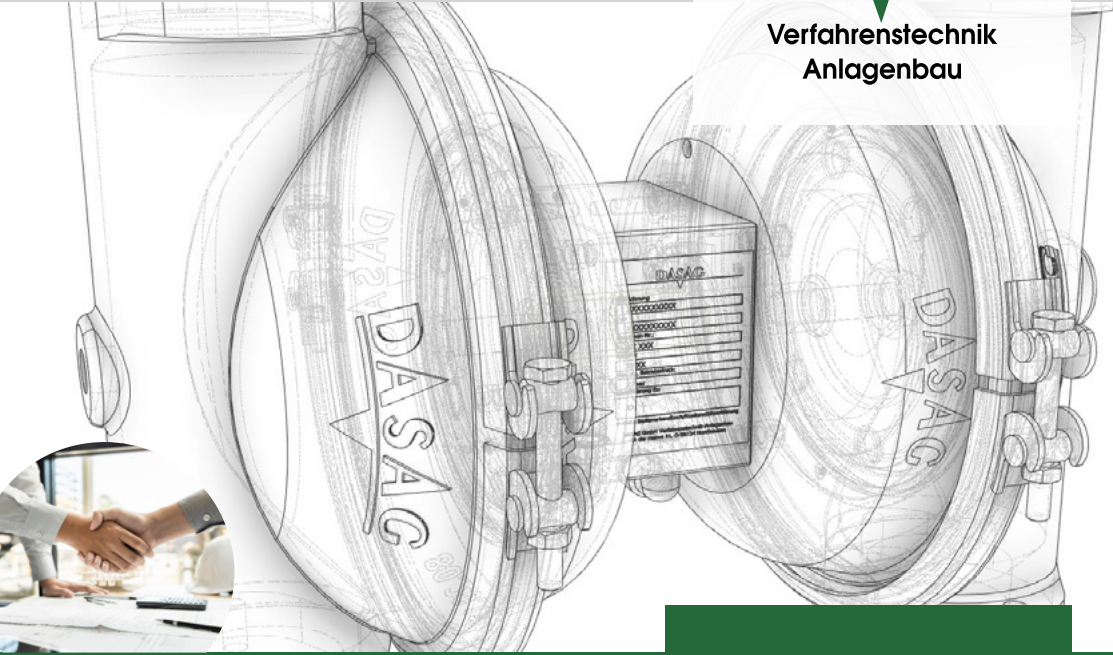

Your Powerful Partner In Terms Of  
**Powder Pumps**

*Innovative  
Solutions For Your  
Bulk Material  
Handling*

# One-stop solutions for your bulk material

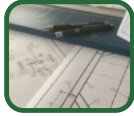

ENGINEERING



MANUFACTURING



ASSEMBLY



AUTOMATION



COMMISSIONING



AFTER-SALES  
SERVICE

## OUR SERVICE PROFILE

✓ Entire turnkey solutions for industries handling bulk materials that comprise the following process stages:

- Trading unit acceptance /emptying
- Storage
- Conveying
- Dosing
- Mixing
- Filling

✓ Engineering / Project planning

✓ Trial and Rental Systems

✓ DASAG –Powder Pumps

✓ After-Sales Services (Maintenance / Spare Parts / System Modernisation / Training)

➡ Your powerful partner for the following industries:

Chemistry, Colours / Varnishes and Adhesives, Cement / Building Materials, Salt Extraction and -Treatment, Power Plants / Waste Incinerators

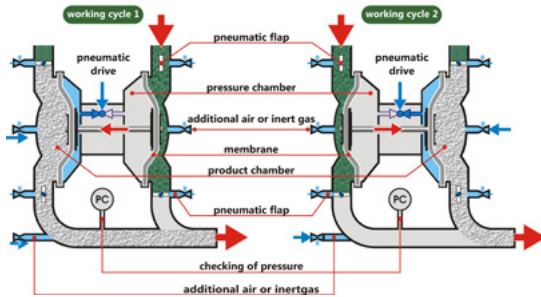

## DASAG – POWDER PUMP

- ✓ Double diaphragm pump specifically designed for conveying powders and granulates
- ✓ Successful on the market for more than 25 years and in over 500 applications, with more than 200 different bulk goods
- ✓ Versatile fields of application under silo systems, trading unit emptying systems, mixing systems, etc.
- ✓ Conveying rate of up to 10 m<sup>3</sup> / h
- ✓ Most advantageous conveying distance up to 80 m
- ✓ Suitable for heavy powders (bulk density > 0.5 kg / dm<sup>3</sup>)
- ✓ Due to gentle conveying especially suitable for difficult to handle bulk materials
- ✓ Can be used as a dosing element in batch processes
- ✓ Approved for use in explosive areas
- ✓ For system pressures < 0.5 bar ➡ no special testing according to Pressure Equipment Directive required

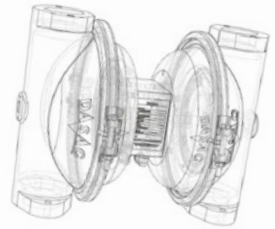

## WORKING PRINCIPLE

- ✓ Double diaphragm pump as a completely pneumatically operated conveyor system
- ✓ Utilisation of gravity principle for material feeding and emptying
- ✓ Electro-pneumatically actuated butterfly valves at the in- and outlets of the pump chambers to release feeding / emptying and to regulate the chamber filling level
- ✓ All parameters for pump drive, air supply and chamber filling level are adjustable by a PLC
- ✓ Pneumatic connections for controlled air supply for fluidization and conveying
- ✓ Two alternately working cycles for feeding and emptying





## USE CASES OF BIG BAG – DOSING STATION

- ✓ Dosing scales with BIG BAG as a flexible dosing hopper
- ✓ BIG BAG-filling optionally either via an integrated electrical chain hoist or by a forklift
- ✓ DASAG -Powder Pump as a discharge aid, conveying device or dosing device
- ✓ Self-sufficient design with an integrated control system



BIG BAG -dosing station with a DASAG -Powder Pump

# DASAG

Verfahrenstechnik  
Anlagenbau



**DASAG GmbH**  
**Verfahrenstechnik – Anlagenbau**  
An der Helme 21  
D-99734 Nordhausen



+49 3631 460 830  
+49 3631 460 8320

info@dasag-verfahrenstechnik.de  
www.dasag-verfahrenstechnik.de